

Systematic Circuit Analysis (T&R Chap 3)

Node-voltage analysis

Using the voltages of the each node relative to a ground node, write down a set of consistent linear equations for these voltages

Solve this set of equations using, say, Cramer's Rule

Mesh current analysis

Using the loop currents in the circuit, write down a set of consistent linear equations for these variables. Solve.

This introduces us to procedures for *systematically* describing circuit variables and solving for them

Nodal Analysis

Node voltages

Pick one node as the ground node 

Label all other nodes and assign voltages v_A, v_B, \dots, v_N
and currents with each branch i_1, \dots, i_M

Recognize that the voltage across a branch
is the difference between the end node
voltages

Thus $v_3 = v_B - v_C$ with the direction
as indicated

Write down the KCL relations at each node

Write down the branch $i-v$ relations to express branch
currents in terms of node voltages

Accommodate current sources

Obtain a set of linear equations for the node voltages

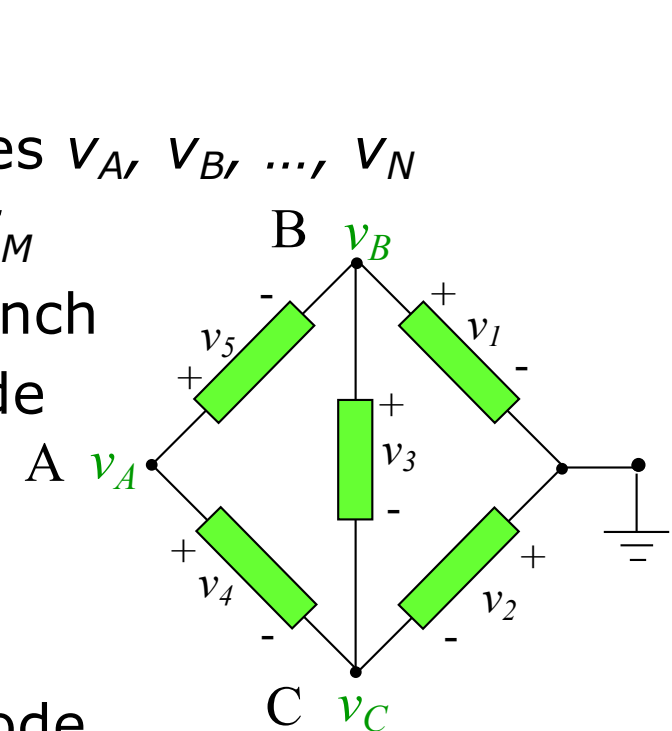

Nodal Analysis – Ex 3-1 (T&R, 5th ed, p.72)

Apply KCL

Write the element/branch eqns

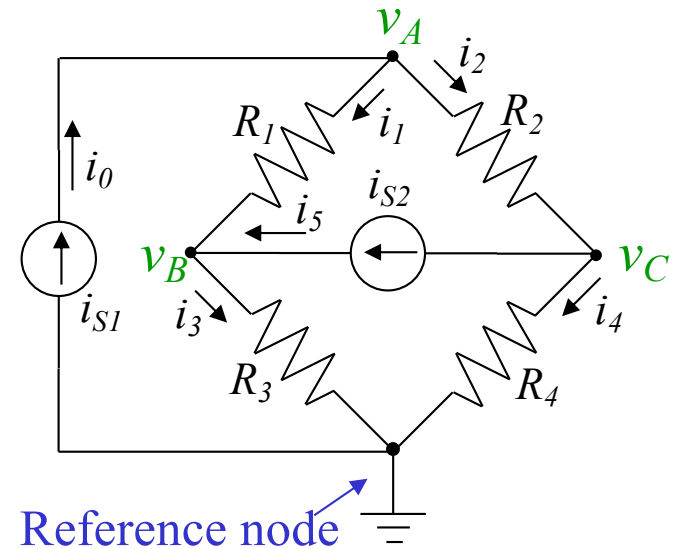

Substitute to get node voltage equations

Solve for v_A , v_B , v_C then i_0 , i_1 , i_2 , i_3 , i_4 , i_5

Nodal Analysis – Ex 3-1 (T&R, 5th ed, p.72)

Apply KCL

$$\text{Node A: } i_0 - i_1 - i_2 = 0$$

$$\text{Node B: } i_1 - i_3 + i_5 = 0$$

$$\text{Node C: } i_2 - i_4 - i_5 = 0$$

Write the element/branch eqns

$$i_0 = i_{S1} \qquad i_3 = G_3 v_B$$

$$i_1 = G_1 (v_A - v_B) \qquad i_4 = G_4 v_C$$

$$i_2 = G_2 (v_A - v_C) \qquad i_5 = i_{S2}$$

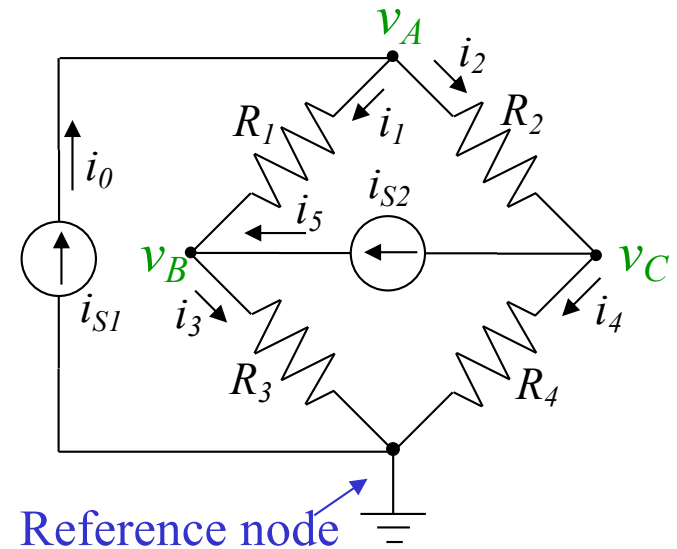

Substitute to get node voltage equations

$$\begin{array}{l} \text{Node A: } (G_1 + G_2)v_A - G_1v_B - G_2v_C = i_{S1} \\ \text{Node B: } -G_1v_A + (G_1 + G_3)v_B = i_{S2} \\ \text{Node C: } -G_2v_A + (G_2 + G_4)v_C = -i_{S2} \end{array} \quad \begin{pmatrix} G_1 + G_2 & -G_1 & -G_2 \\ -G_1 & G_1 + G_3 & 0 \\ -G_2 & 0 & G_2 + G_4 \end{pmatrix} \begin{pmatrix} v_A \\ v_B \\ v_C \end{pmatrix} = \begin{pmatrix} i_{S1} \\ i_{S2} \\ -i_{S2} \end{pmatrix}$$

Solve for v_A, v_B, v_C then $i_0, i_1, i_2, i_3, i_4, i_5$

Systematic Nodal Analysis

$$\begin{pmatrix} G_1+G_2 & -G_1 & -G_2 \\ -G_1 & G_1+G_3 & 0 \\ -G_2 & 0 & G_2+G_4 \end{pmatrix} \begin{pmatrix} v_A \\ v_B \\ v_C \end{pmatrix} = \begin{pmatrix} i_{S1} \\ i_{S2} \\ -i_{S2} \end{pmatrix}$$

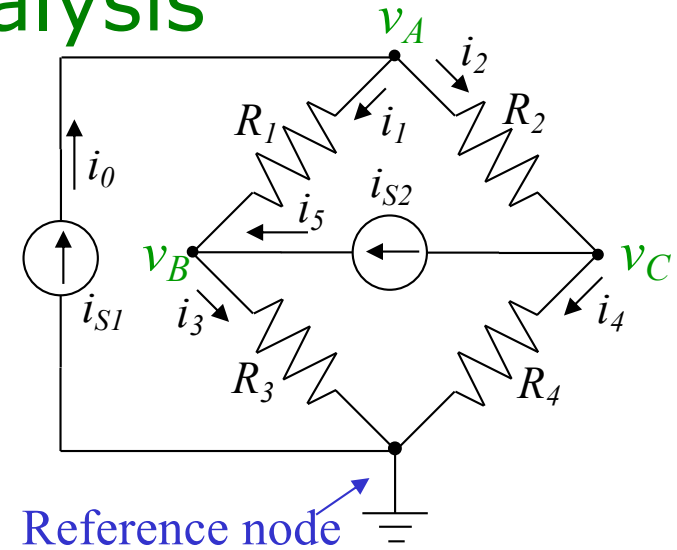

Writing node equations by inspection

Note that the matrix equation looks

just like $\underline{G}\underline{v}=\underline{i}$ for matrix \underline{G} and vector \underline{v} and \underline{i}
 \underline{G} is symmetric (and non-negative definite)

Diagonal (i,i) elements: sum of all conductances connected to node i

Off-diagonal (i,j) elements: -conductance between nodes i and j

Right-hand side: current sources entering node i

There is no equation for the ground node – the column sums give the conductance to ground

Nodal Analysis Ex. 3-2 (T&R, 5th ed, p.74)

Node A:

Conductances

Source currents entering

Node B:

Conductances

Node C:

Conductances

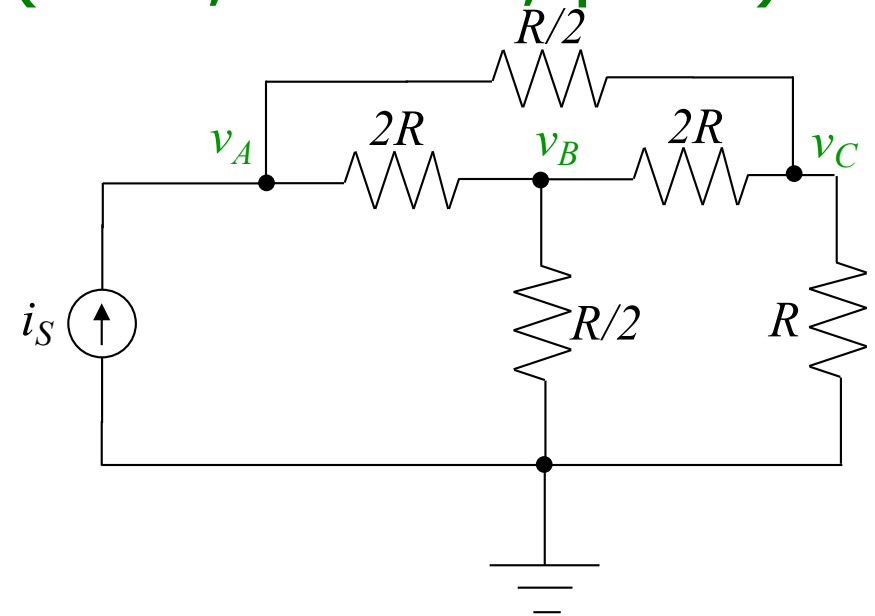

Source currents entering

Source currents entering

Nodal Analysis Ex. 3-2 (T&R, 5th ed, p.74)

Node A:

Conductances

$$G/2_B + 2G_C = 2.5G$$

Source currents entering = i_S

Node B:

Conductances

$$G/2_A + G/2_C + 2G_{ground} = 3G$$

Node C:

Conductances

$$2G_A + G/2_B + G_{ground} = 3.5G$$

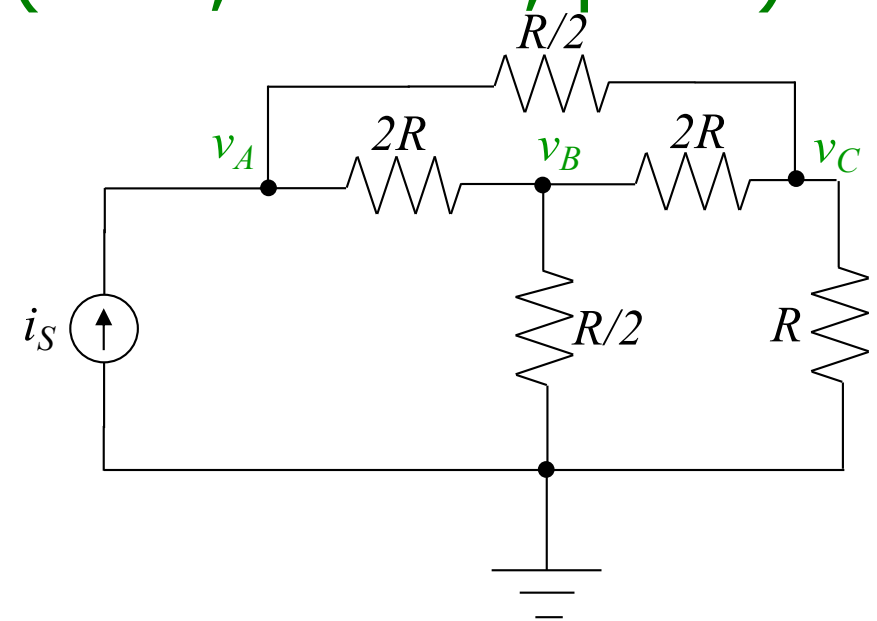

Source currents entering = 0

Source currents entering = 0

$$\begin{pmatrix} 2.5G & -0.5G & -2G \\ -0.5G & 3G & -0.5G \\ -2G & -0.5G & 3.5G \end{pmatrix} \begin{pmatrix} v_A \\ v_B \\ v_C \end{pmatrix} = \begin{pmatrix} i_S \\ 0 \\ 0 \end{pmatrix}$$

Nodal Analysis – some points to watch

1. The formulation given is based on KCL with the sum of currents ***leaving*** the node

$$0 = i_{total} = G_{AtoB}(V_A - V_B) + G_{AtoC}(V_A - V_C) + \dots + G_{AtoGround}V_A + i_{leavingA}$$

This yields

$$0 = (G_{AtoB} + \dots + G_{AtoGround})V_A - G_{AtoB}V_B - G_{AtoC}V_C \dots - i_{enteringA}$$

$$(G_{AtoB} + \dots + G_{AtoGround})V_A - G_{AtoB}V_B - G_{AtoC}V_C \dots = i_{enteringA}$$

2. If in doubt about the sign of the current source, go back to this basic KCL formulation
3. This formulation works for independent current sources

For dependent current sources (introduced later) use your wits

Nodal Analysis Ex. 3-2 (T&R, 5th ed, p. 72)

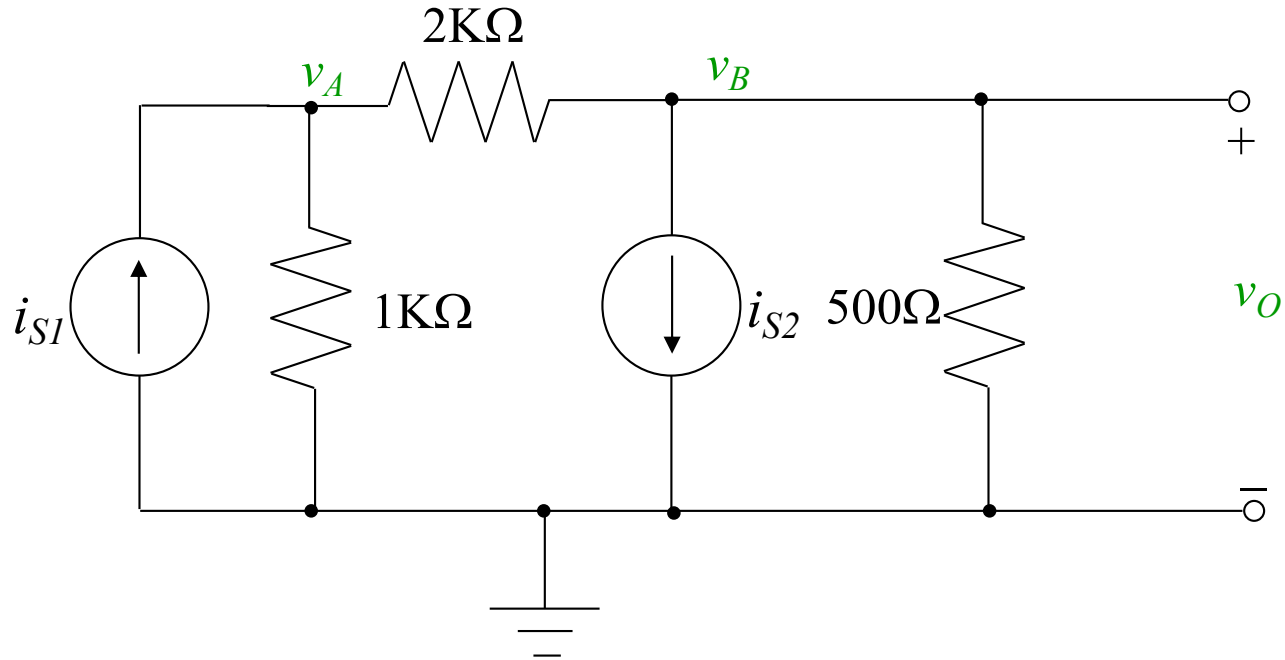

Nodal Analysis Ex. 3-2 (T&R, 5th ed, p. 72)

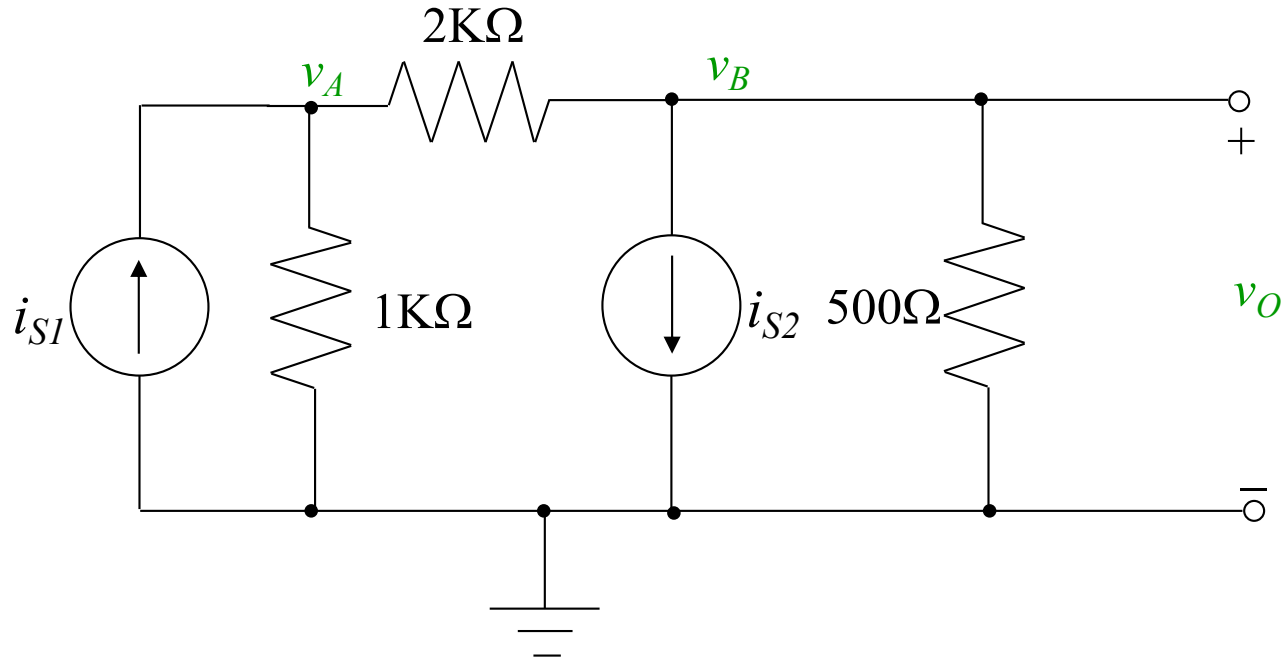

$$\begin{pmatrix} 1.5 \times 10^{-3} & -0.5 \times 10^{-3} \\ -0.5 \times 10^{-3} & 2.5 \times 10^{-3} \end{pmatrix} \begin{pmatrix} v_A \\ v_B \end{pmatrix} = \begin{pmatrix} i_{S1} \\ -i_{S2} \end{pmatrix}$$

Solve this using standard linear equation solvers

Cramer's rule

Gaussian elimination

Matlab

Nodal Analysis with Voltage Sources

Current through voltage source is not computable from voltage across it. We need some tricks!

They actually help us simplify things

Method 1 – source transformation

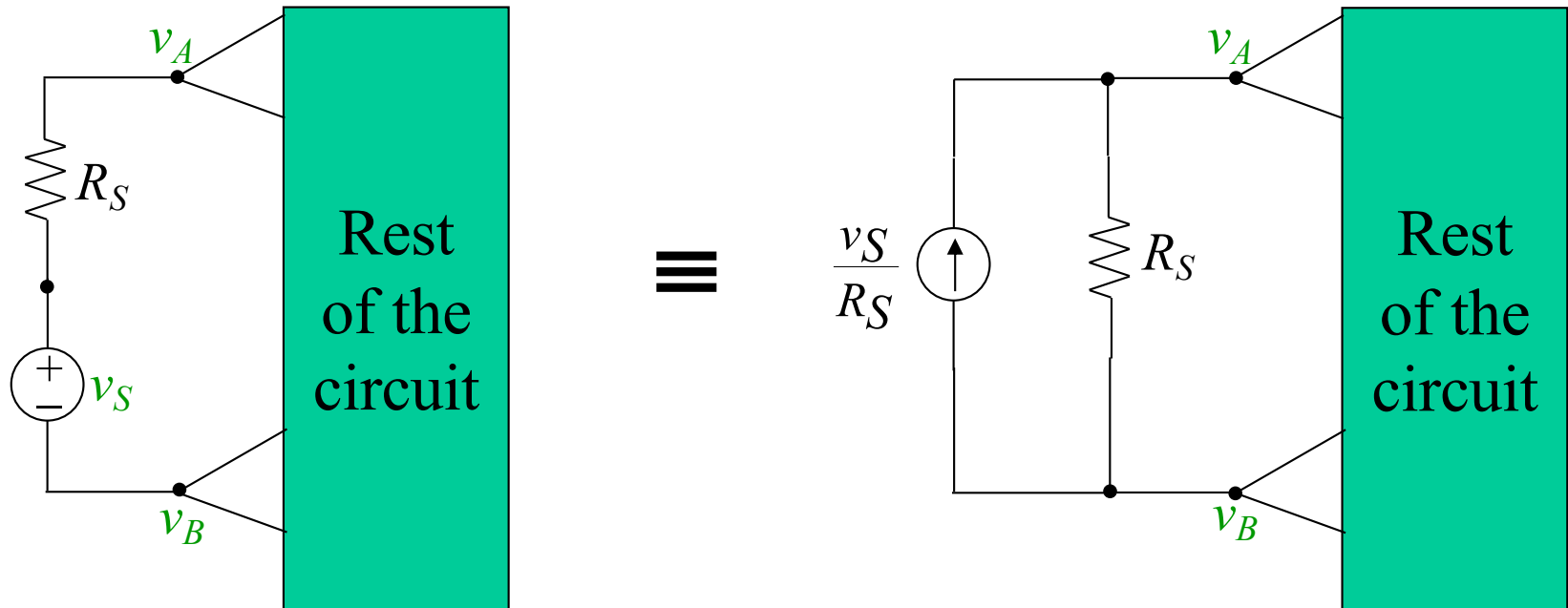

Then use standard nodal analysis – one less node!

Nodal Analysis with Voltage Sources 2

Method 2 – grounding one node

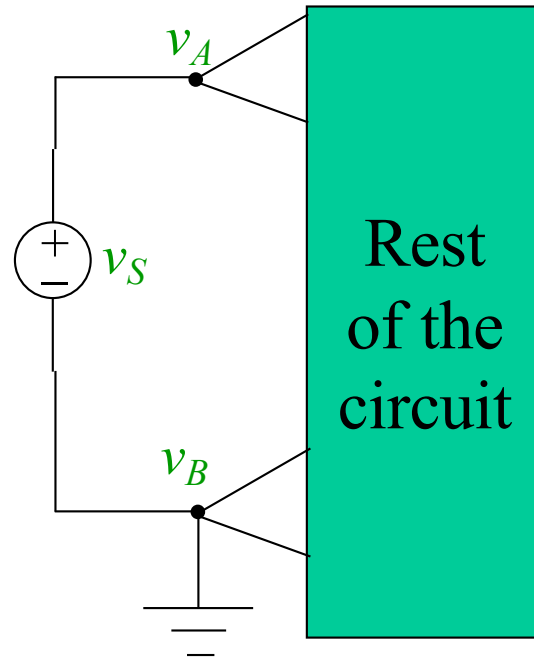

This removes the v_B variable
(plus we know $v_A = v_S$) – simpler analysis
But can be done once per circuit

Nodal Analysis with Voltage Sources 3

Method 3

Create a *supernode*

Act as if A and B were one node

KCL still works for this node

Sum of currents entering
supernode box is 0

Write KCL at all $N-3$ other nodes

($N-2$ nodes less Ground node)

using v_A and v_B as usual

+Write one supernode KCL

+Add the constraint $v_A - v_B = v_S$

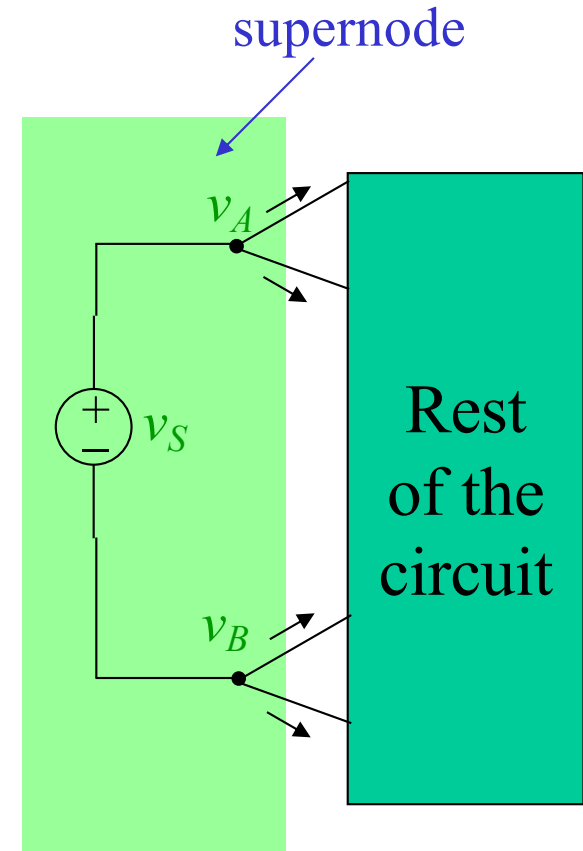

These three methods allow us to deal with all cases

Nodal Analysis Ex. 3-4 (T&R, 5th ed, p. 76)

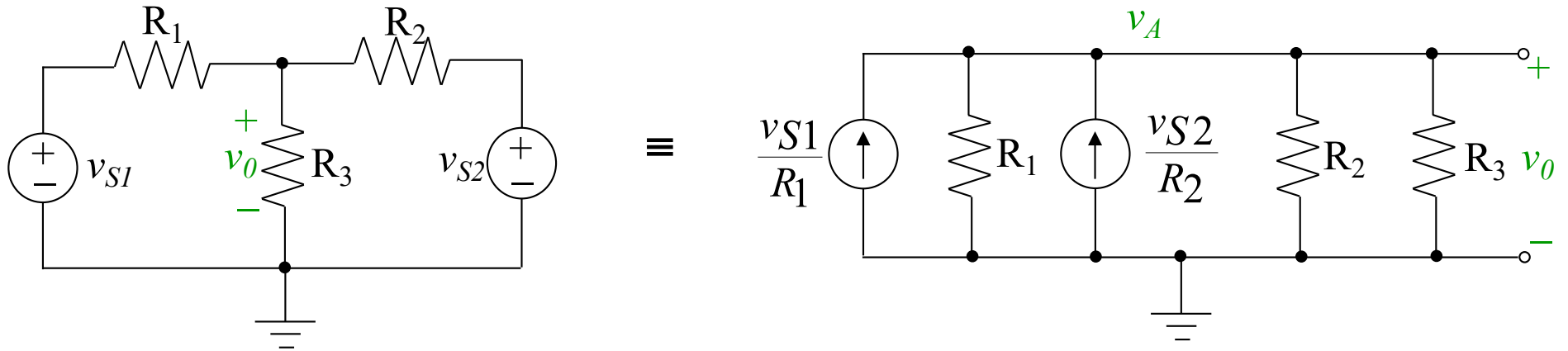

This is method 1 – transform the voltage sources

Applicable since voltage sources appear in series with Resist

Now use nodal analysis with one node, A

Nodal Analysis Ex. 3-4 (T&R, 5th ed, p. 76)

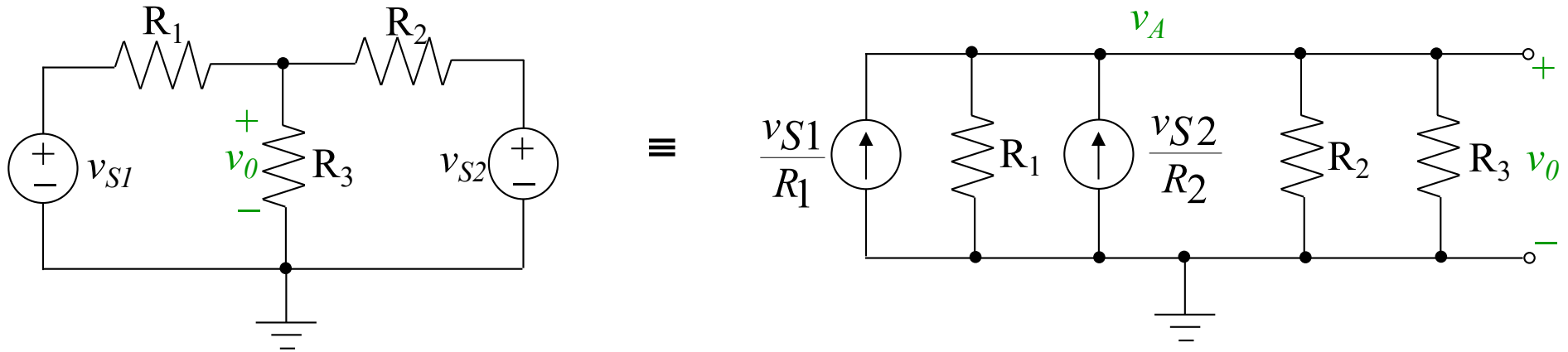

This is method 1 – transform the voltage sources

Applicable since voltage sources appear in series with Resist

Now use nodal analysis with one node, A

$$(G_1 + G_2 + G_3)v_A = G_1v_{S1} + G_2v_{S2}$$

$$v_A = \frac{G_1v_{S1} + G_2v_{S2}}{G_1 + G_2 + G_3}$$

Nodal Analysis Ex. 3-5 (T&R, 5th ed, p. 77)

What is the circuit input resistance viewed through v_S ?

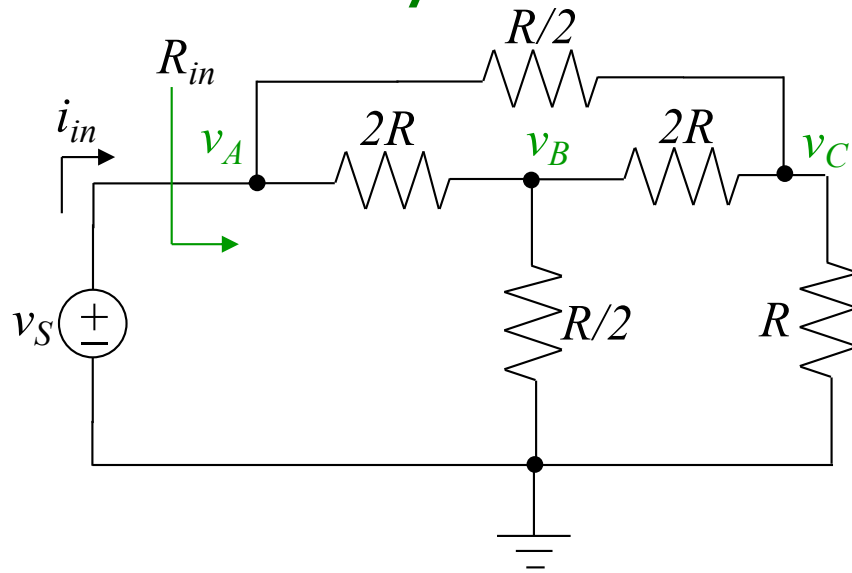

Nodal Analysis Ex. 3-5 (T&R, 5th ed, p. 77)

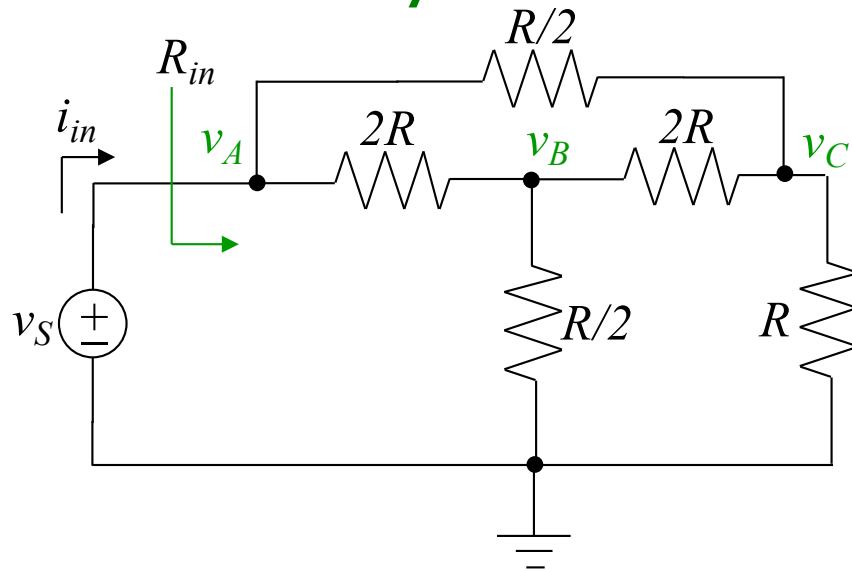

What is the circuit input resistance viewed through v_S ?

$$v_A = v_S$$

$$-0.5Gv_A + 3Gv_B - 0.5Gv_C = 0$$

$$-2Gv_A - 0.5Gv_B + 3.5Gv_C = 0$$

Rewrite in terms of v_S, v_B, v_C

This is method 2

$$3Gv_B - 0.5Gv_C = 0.5Gv_S$$

$$-0.5Gv_B = 3.5Gv_C - 2Gv_S$$

$$v_B = \frac{2.75v_S}{10.25}, v_C = \frac{6.25v_S}{10.25}$$

Solve

$$i_{in} = \frac{v_S - v_B}{2R} + \frac{v_S - v_C}{R/2} = \frac{11.75v_S}{10.25R}$$

$$R_{in} = \frac{10.25R}{11.75} = 0.872R$$

Nodal Analysis Ex. 3-6 (T&R, 5th ed, p. 78)

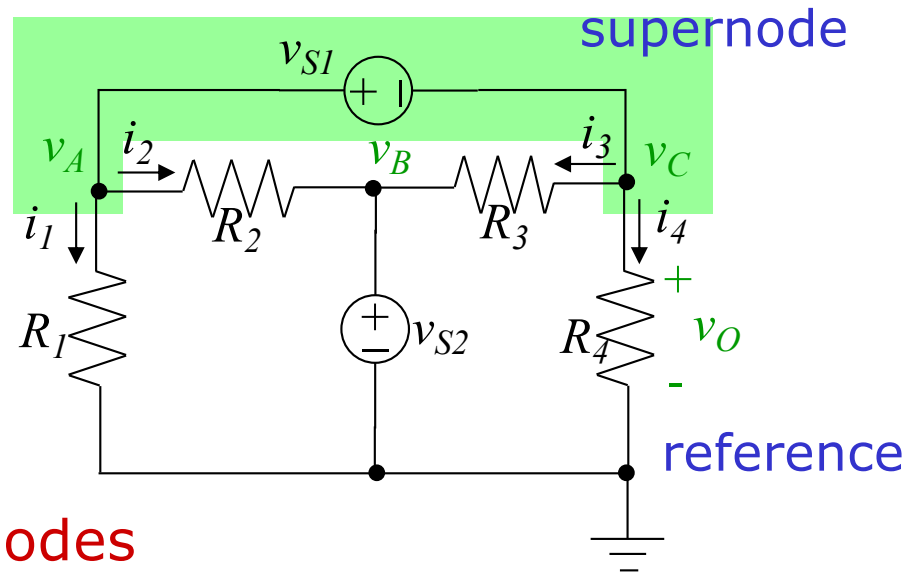

Method 3 – supernodes

Nodal Analysis Ex. 3-6 (T&R, 5th ed, p. 78)

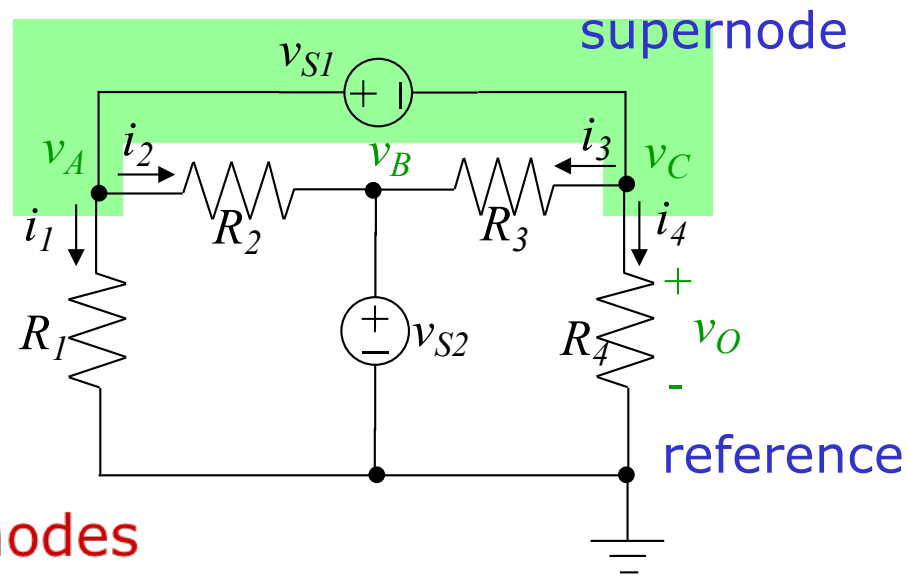

Method 3 – supernodes

KCL for supernode: $i_1 + i_2 + i_3 + i_4 = 0$

Or, using element equations

$$G_1 v_A + G_2 (v_A - v_B) + G_3 (v_C - v_B) + G_4 v_C = 0$$

Now use $v_B = v_{S2}$

$$(G_1 + G_2) v_A + (G_3 + G_4) v_C = (G_2 + G_3) v_{S2}$$

Other constituent relation

$$v_A - v_C = v_{S1}$$

Two equations in two unknowns

Mesh Current Analysis

Dual of Nodal Voltage Analysis with KCL

Mesh Current Analysis with KVL

Mesh = loop enclosing no elements

Restricted to Planar Ccts – no crossovers (unless you are really clever)

Key Idea: *If element K is contained in both mesh i and mesh j then its current is $i_k = i_i - i_j$ where we have taken the reference directions as appropriate*

Same old tricks you already know

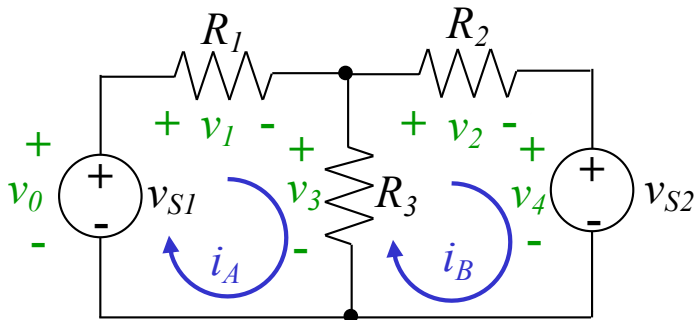

$$\begin{aligned} \text{Mesh A: } -v_0 + v_1 + v_3 &= 0 & v_1 &= R_1 i_A & v_0 &= v_{S1} \\ \text{Mesh B: } -v_3 + v_2 + v_4 &= 0 & v_2 &= R_2 i_B & v_4 &= v_{S2} \\ & & v_3 &= R_3 (i_A - i_B) & & \end{aligned}$$

$$\begin{aligned} (R_1 + R_3) i_A - R_3 i_B &= v_{S1} \\ -R_3 i_A + (R_2 + R_3) i_B &= -v_{S2} \end{aligned}$$

$$\begin{pmatrix} R_1 + R_3 & -R_3 \\ -R_3 & R_2 + R_3 \end{pmatrix} \begin{pmatrix} i_A \\ i_B \end{pmatrix} = \begin{pmatrix} v_{S1} \\ -v_{S2} \end{pmatrix}$$

Mesh Analysis by inspection $Ri \square v_S$

Matrix of Resistances R

Diagonal ii elements: sum of resistances around loop

Off-diagonal ij elements: - resistance shared by loops i and j

Vector of currents i

As defined by you on your mesh diagram

Voltage source vector v_S

Sum of voltage sources **assisting** the current in your mesh

If this is hard to fathom, go back to the basic KVL to sort these directions out

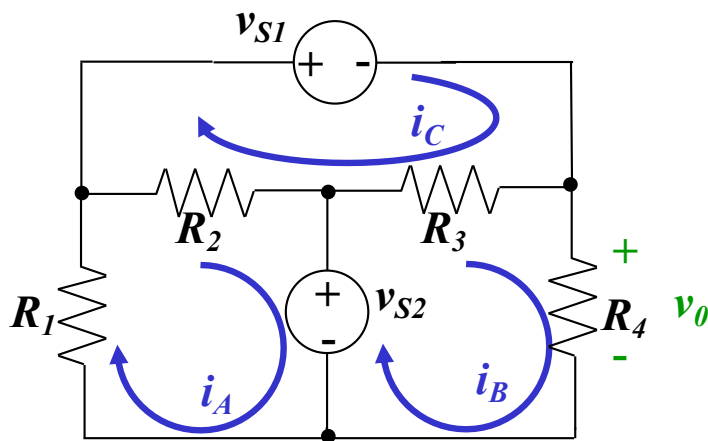

Mesh Analysis by inspection $Ri = v_S$

Matrix of Resistances R

Diagonal ii elements: sum of resistances around loop

Off-diagonal ij elements: - resistance shared by loops i and j

Vector of currents i

As defined by you on your mesh diagram

Voltage source vector v_S

Sum of voltage sources **assisting** the current in your mesh

If this is hard to fathom, go back to the basic KVL to sort these directions out

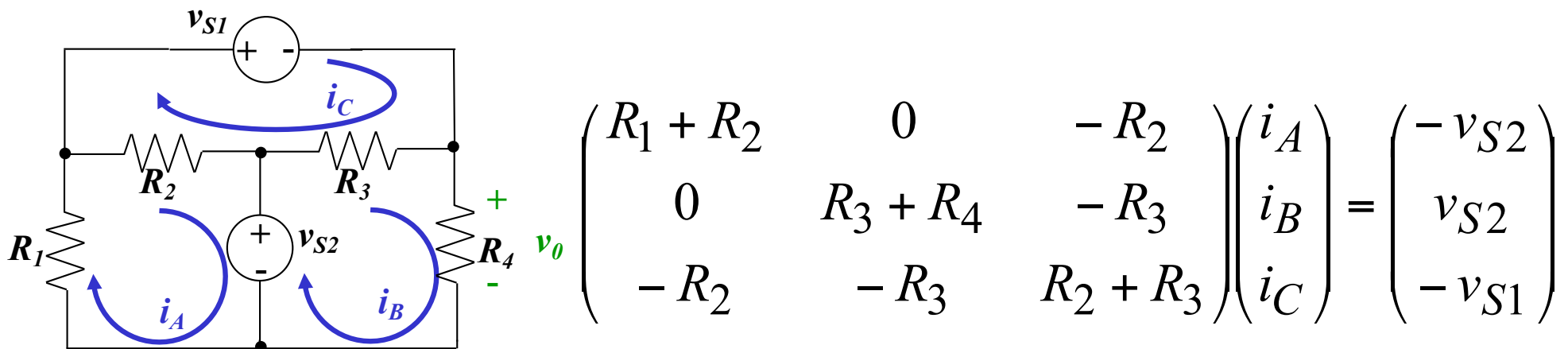

Mesh Equations with Current Sources

Duals of tricks for nodal analysis with voltage sources

1. Source transformation to equivalent

T&R, 5th ed, Example 3-8 p. 91

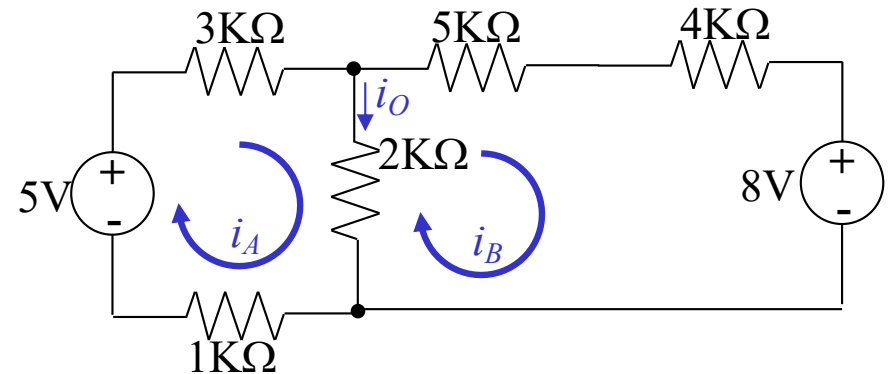
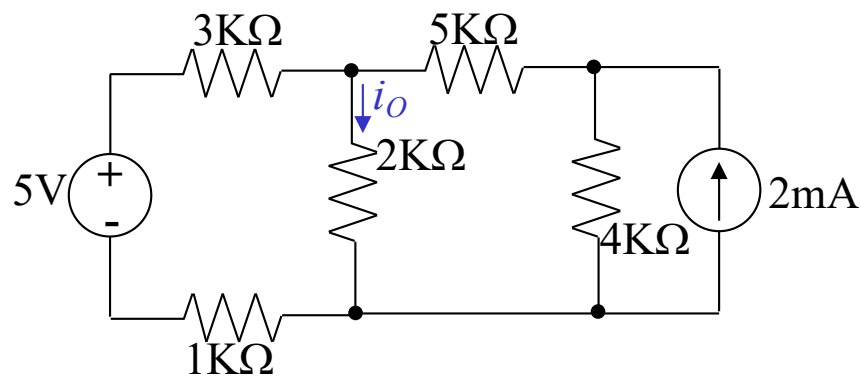

$$\begin{pmatrix} 6000 & -2000 \\ -2000 & 11000 \end{pmatrix} \begin{pmatrix} i_A \\ i_B \end{pmatrix} = \begin{pmatrix} 5 \\ -8 \end{pmatrix}$$

$$i_A = 0.6290 \text{ mA}$$

$$i_B = -0.6129 \text{ mA}$$

$$i_O = i_A - i_B = 1.2419 \text{ mA}$$

Mesh Analysis with ICSs – method 2

Current source belongs to a single mesh

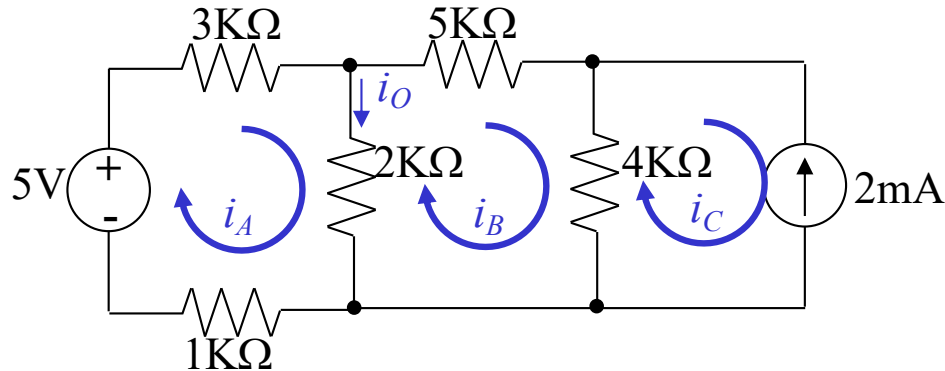

Same example

$$6000i_A - 2000i_B = 5$$

$$-2000i_A + 11000i_B - 4000i_C = 0$$

$$i_C = -2\text{mA}$$

Same equations!
Same solution

Mesh Analysis with ICSs – Method 3

Supermeshes – easier than supernodes

Current source in more than one mesh and/or not in parallel with a resistance

1. Create a supermesh by eliminating the whole branch involved
2. Resolve the individual currents last

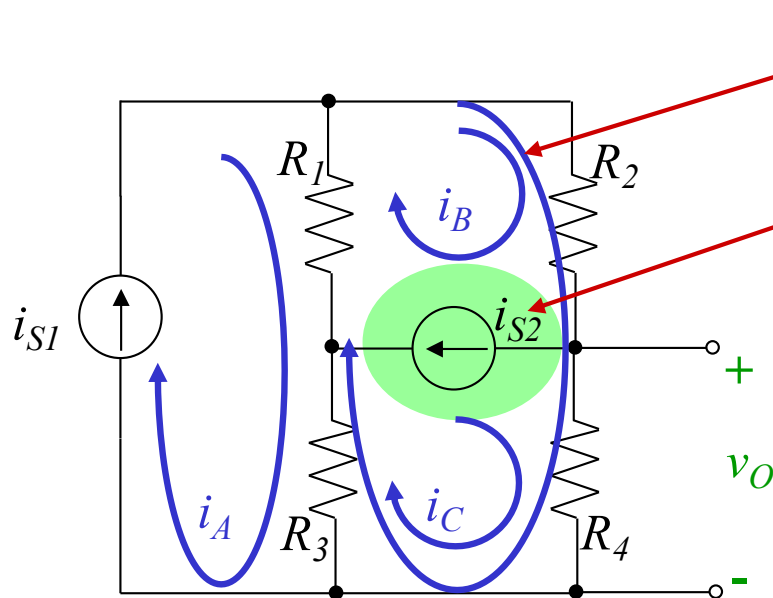

Supermesh

Excluded branch

$$R_1(i_B - i_A) + R_2 i_B + R_4 i_C + R_3(i_C - i_A) = 0$$

$$i_A = i_{S1}$$

$$i_B - i_C = i_{S2}$$

Exercise from old midterm

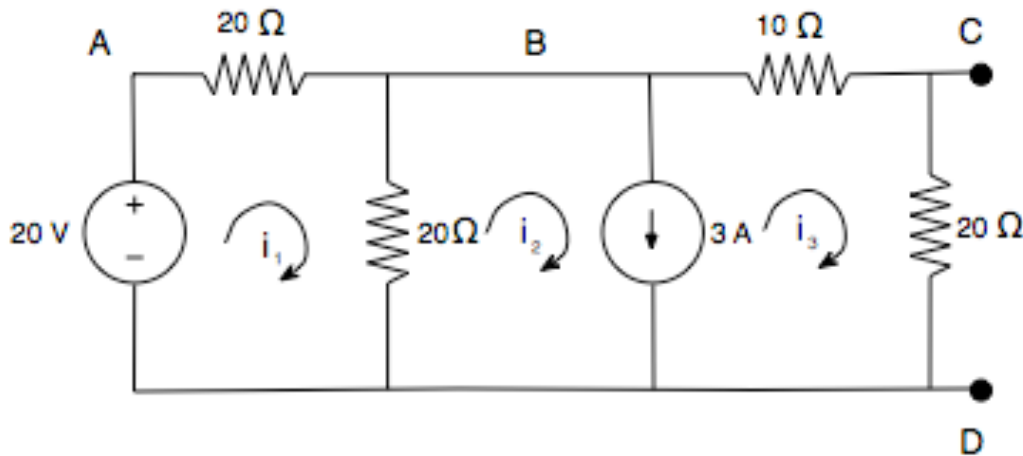

Set up mesh analysis equations

Do not use any source transformation!

Supermesh

$$i_2 - i_3 = 3$$

$$10i_3 + 20i_3 + 20(i_2 - i_1) = 0$$

Remaining mesh

$$20i_1 + 20(i_1 - i_2) = 20$$

Summary of Mesh Analysis

1. Check if cct is planar or transformable to planar
2. Identify meshes, mesh currents & supermeshes
3. Simplify the cct where possible by combining elements in series or parallel
4. Write KVL for each mesh
5. Include expressions for ICSs
6. Solve for the mesh currents

Linearity & Superposition

Linear cct – modeled by linear elements and independent sources

Linear functions

Homogeneity: $f(Kx) = Kf(x)$

Additivity: $f(x+y) = f(x) + f(y)$

Superposition – follows from linearity/additivity

Linear cct response to multiple sources is the sum of the responses to each source

1. “Turn off” all independent sources except one and compute cct variables
2. Repeat for each independent source in turn
3. Total value of all cct variables is the sum of the values from all the individual sources

Superposition

Turning off sources

Voltage source

Turned off when $v=0$ for all i
a short circuit

Current source

Turned off when $i=0$ for all v
an open circuit

We have already used this in
Thévenin and Norton equiv

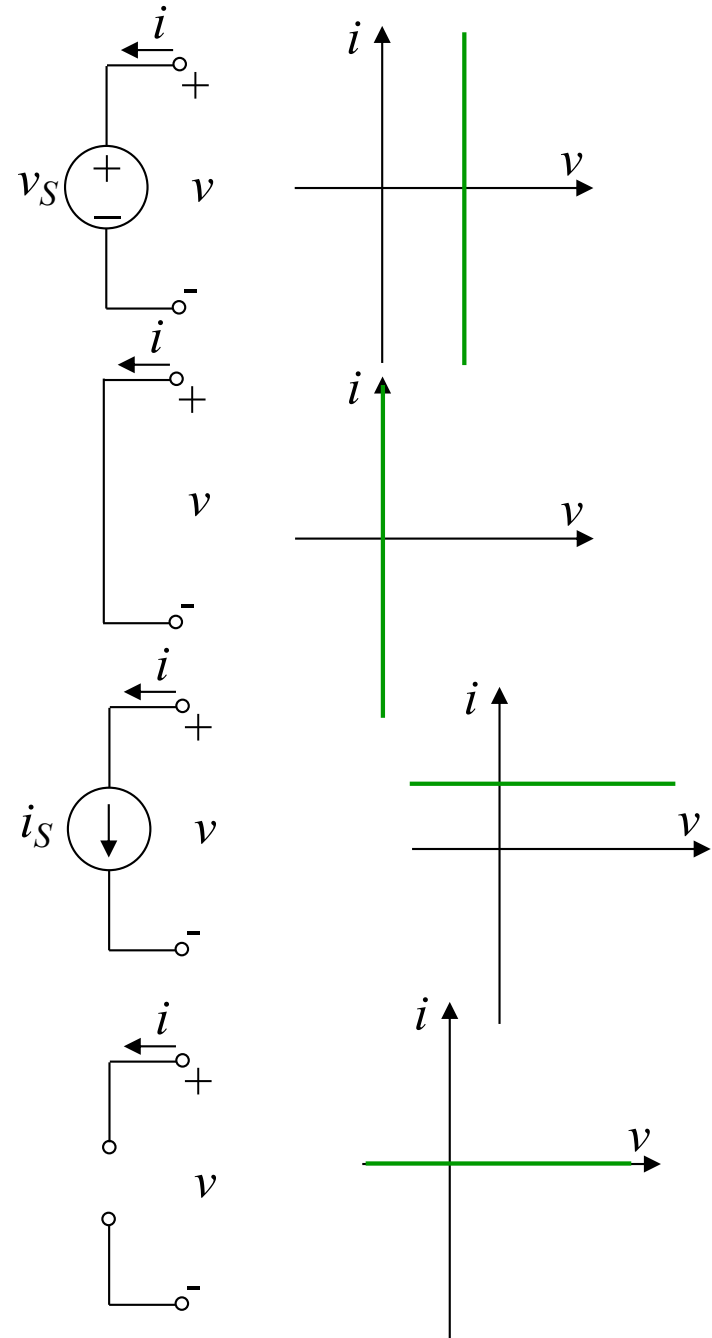

Superposition

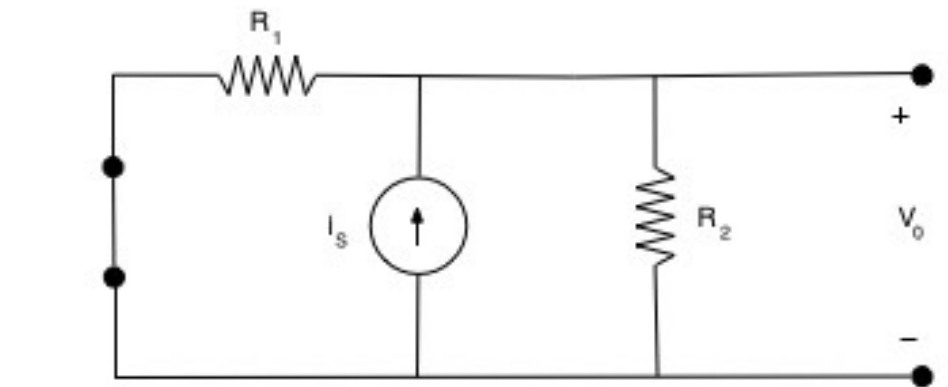
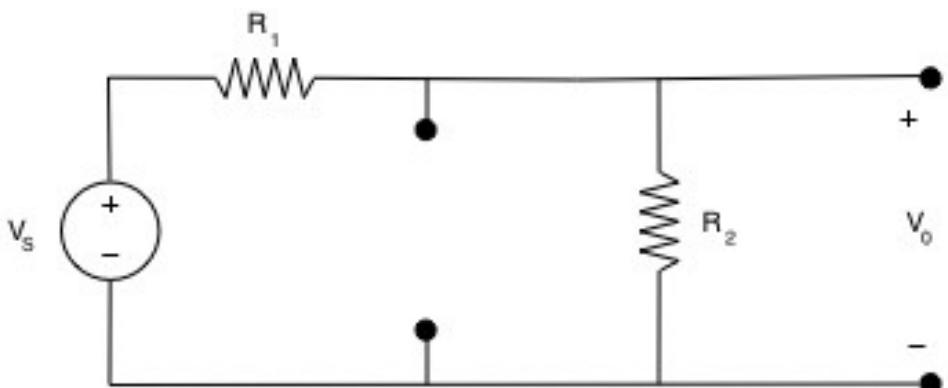
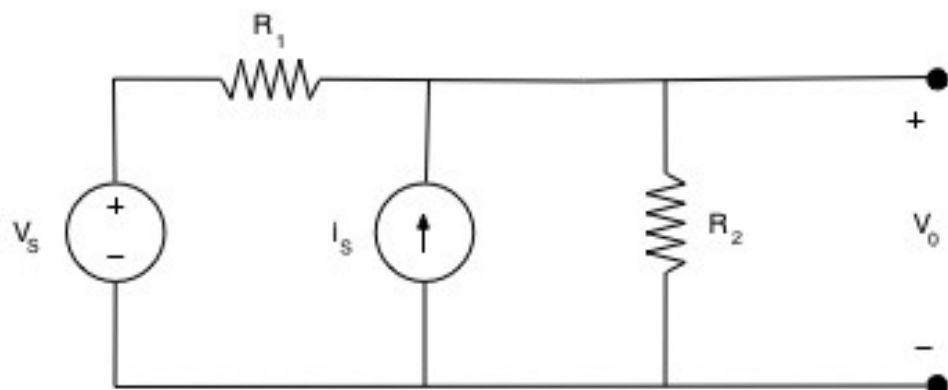

MAE40 Linear Circuits

Find v_o using superposition

$$v_o = \frac{R_2}{R_1 + R_2} v_s + \frac{R_1 R_2}{R_1 + R_2} i_s$$

$$v_{o1} = \frac{R_2}{R_1 + R_2} v_s$$

$$v_{o2} = \frac{R_1 R_2}{R_1 + R_2} i_s$$

Where are we now?

Finished resistive ccts with ICS and IVS

Two analysis techniques – nodal voltage and mesh current

Preference depends on simplicity of the case at hand

The aim has been to develop general techniques for access to tools like matlab

Where to now?

Active ccts with resistive elements – transistors, op-amps

Life starts to get interesting – getting closer to design

Capacitance and inductance – dynamic ccts

Frequency response – s -domain analysis

Filters